



COMPACT DESIGN
BIG PERFORMANCE

ENG

G2700

HD / X-TRA HD / TELE HD /
HD+ / X-TRA HD+ /
TELE HD+



GiANT[®]
BY TOBROCO

WWW.TOBROCO-GIANT.COM



G2700

HD / X-TRA HD / TELE HD /
HD+ / X-TRA HD+ /
TELE HD+

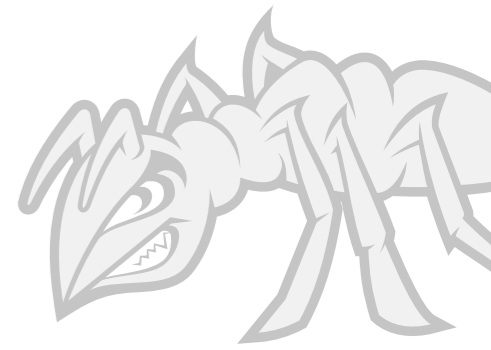

COMPACT DESIGN, BIG PERFORMANCE



DISTINCTIVE POWER

Like all GIANT machines the G2700 models will distinguish themselves by their compact size and by a high tipping load compared to their own weight. The articulated pendulum swing system gives the G2700 a tight turning circle and allows the machine to operate in tight spaces.

TOBROCO-GIANT works closely with quality suppliers like Bosch Rexroth, Comer, Kubota and Hydac during the development of new machines.



The dynamic G2700 is a true force to be reckoned with, boasting impressive tipping loads and lifting power. It effortlessly handles substantial tasks while remaining conveniently transportable on a trailer. Whether you're conquering challenges in infrastructure, thriving on construction sites, sculpting landscapes, or conquering earth-moving projects, the G2700 is your all-season, all-sector solution.

TYPES	G2700 HD	G2700 X-TRA HD	G2700 HD+	G2700 X-TRA HD+	G2700 TELE HD	G2700 TELE HD+
Service weight ¹	2.550 kg	2.550 kg	2.600 kg	2.600 kg	2.950 kg	3.000 kg
Lifting capacity	1.875 kg	2.325 kg	1.900 kg	2.350 kg	2.325 kg	2.350 kg
Tipping load	2.070 kg	2.220 kg	2.225 kg	2.455 kg	see graph page 17	see graph page 17
Lifting height	2.964 mm	2.500 mm	2.964 mm	2.500 mm	3.711 mm	3.711 mm
Length without bucket	3.405 mm	3.468 mm	3.405 mm	3.468 mm	3.625 mm	3.625 mm
Width	1.100 mm	1.100 mm	1.140 mm	1.140 mm	1.100 mm	1.140 mm
Machine height	2.340 mm	2.340 mm	2.340 mm	2.340 mm	2.340 mm	2.340 mm

¹ Measured with standard version and earthbucket.

STRONG PROPERTIES



- 1. WORKING COMFORTABLY** - A comfortable working environment has been created in the cabin, therefore long working days are no problem.
- 2. WORK SAFELY** - The cabin and safety roof ROPS/FOPS certified on international standard. The use of narrow styles and skylight gives the operator all-round visibility and an excellent view on his work to allow safe and precise operation.
- 3. EASY SERVICE** - Daily checks and maintenance can be carried out quickly and in a safe manner because service points are easily accessible.
- 4. POWERFUL PERFORMANCE** - The machines are driven by a powerful 50 hp Kubota engine which is equipped with a catalytic converter (DOC) and soot filter (DPF) and meets the latest EU Stage V standards for clean engines.
- 5. COMPACT DESIGN** - The compact dimensions ensure that the machines can operate in small spaces. And even can be used indoors.
- 6. MANEUVERABILITY AND STABILITY** - The articulated pendulum joint provides manoeuvrability and stability. Unevenness's are absorbed without any compromise to the performance.

- 7. PRODUCTIVITY** - The hydrostatic 4 wheel drive with automotive control and the 8 (HD and X-TRA HD) or 12 (HD+ and X-TRA HD+) tons axles, always provides enough grip, a lot of pulling force for a smooth movement.
- 8. VERSATILITY** - Simply change the attachments and adjust the machine to your working conditions.
- 9. HYDRAULIC POSSIBILITIES** - The standard double-acting function at the front of the machine (mechanically operated) can easily be expanded with additional hydraulic functions and a tandem pump and Combi-Flow.
- 10. SPEED** - With a travel speed of 25 km/h (HD and X-TRA HD) or 30 km/h (HD+ and X-TRA HD+), the machines can move quickly to the next job site or transport materials in no time.
- 11. CHOOSE THE MACHINE FOR YOUR WORK** - The G2700 can be configured completely according to your wishes. Depending on your work you choose between the HD, X-TRA HD, HD+, TELE HD or TELE HD+ version with matching options.
- 12. 12. SOLID INVESTMENT** - The G2700 is a solid investment because of its reliability and high productivity. Only the best components have been chosen and tested extensively before they were applied.

TOP PERFORMANCE



Both the G2700 HD and the G2700 X-TRA HD have a service weight of 2,550 kg. This gives the model with the standard lifting arm a lifting height of 2.96 meters and tipping load of 2.375 kg. The G2700 X-TRA HD has a lifting height of 2.5 meters and a tipping load of 2,850 kg. The service weight of the G2700 HD+ models is 2,600 kg and this provides a tipping load of 2,400 kg for the G2700 HD+ and 2,900 kg for the G2700 X-TRA HD+ respectively. The G2700 TELE HD features an operating weight of 2,950 kg. The operating weight of the G2700 TELE HD+ is 3,000 kg. Both machines are capable to achieve a lifting height of 3.71 meters.



POWERFUL ENGINE

The G2700 is available in six different models: G2700 HD, G2700 X-TRA HD, G2700 TELE HD, G2700 HD+, G2700 X-TRA HD+ and G2700 TELE HD+. All 6 models are powered by a 3 cylinder Kubota engine with 50 hp. The engine is equipped with DOC and DPF and meets the latest EU Stage V clean engine standards. In addition, all models are powered by a hydrostatic all-wheel drive with automotive steering.

“It’s been worth every penny. It does everything you ask of it and more. I’ve never had such a versatile machine.”

Andy Tubman, Hillsborough



PLANETARY AXELS

The difference between the G2700 (X-TRA) HD and G2700 (X-TRA) HD+ is reflected in the use of different planetary axels in HD version. The G2700 HD, G2700 X-TRA HD and G2700 TELE HD+ are equipped with 8 tons axels with limited slip and these provide a pulling force of 20.000 N and a maximum driving speed of 25 km/h. The G2700 HD+, G2700 X-TRA HD+ and G2700 TELE HD+ are equipped with 12 tons axels and electrically switchable 100% lock on both axels. This powertrain provides a pulling force of 28.000 N and a maximum driving speed of 30 km/h.



STRONG WORKING HYDRAULICS

The hydraulic system of the G2700 models is directly controlled via the joystick and is with 51 l/min (230 bar) more than sufficient to drive a large number of attachments. If the working conditions demand more, then the working hydraulics can be extended to a servo-controlled version and an electrically switchable tandem pump.

COMPACT DESIGN



The powerful G2700 models are designed to operate in small spaces and on rough terrain. Not only the low weight and the compact dimensions ensure this, but also the articulated pendulum joint gives the machines a small turning circle and makes them extremely maneuverable. This ensures that work can be done very accurately.

Depending on the choice of tires, the machines have a width between 110 and 150 centimetres. The machine height for the G2700 with safety roof or cabin is a maximum of 2.34 meters. The maximum machine height with the option for a foldable safety roof with a collapsed safety roof is 1.98 meters. Therefore, narrow and low passages are no problem and the machines can be used inside as well.

The fact that the machines can be transported on a trailer provides flexibility for the user. The G2700 is therefore easy to use in the places where the work requires it.



STABILITY AND MANEUVRABILITY

The articulated pendulum joint provides the G2700 a lot of stability and maneuverability. The system ensures that all four wheels remain always on the ground, even when working on uneven terrain. This allows the driver to work safely while having sufficient traction all the time.

The optional and patented STABILO system enables the operator to fix the pendulum joint, allowing for higher levels of stability in uneven ground conditions.



SAFETY AND COMFORT



In the cabin, a comfortable working environment has been created so long working days are no problem. The steering column is fully adjustable and all necessary information can easily be read from a central display. While using the joystick, the operator can rest his arm on an ergonomically shaped armrest. All key functions are close to the joystick so that they can be operated without effort. Optionally, the machines can be supplied with items that are desirable for the work to be performed.



WORK SAFELY

The G2700 machines are equipped with a safety roof as standard and this can optionally be extended to a full-option cabin. The cabins of the G2700 machines have been extensively tested on safety by an independent authority and are ROPS/FOPS certified by international standard. All-round visibility gives the operator an excellent view on his working area and allows safe and precise operation.



ELECTRONIC CONTROL

Information about oil temperature, regeneration, etc., can be read from the dashboard so that the driver can always see these important data during work.

360° all-round visibility from the cabin

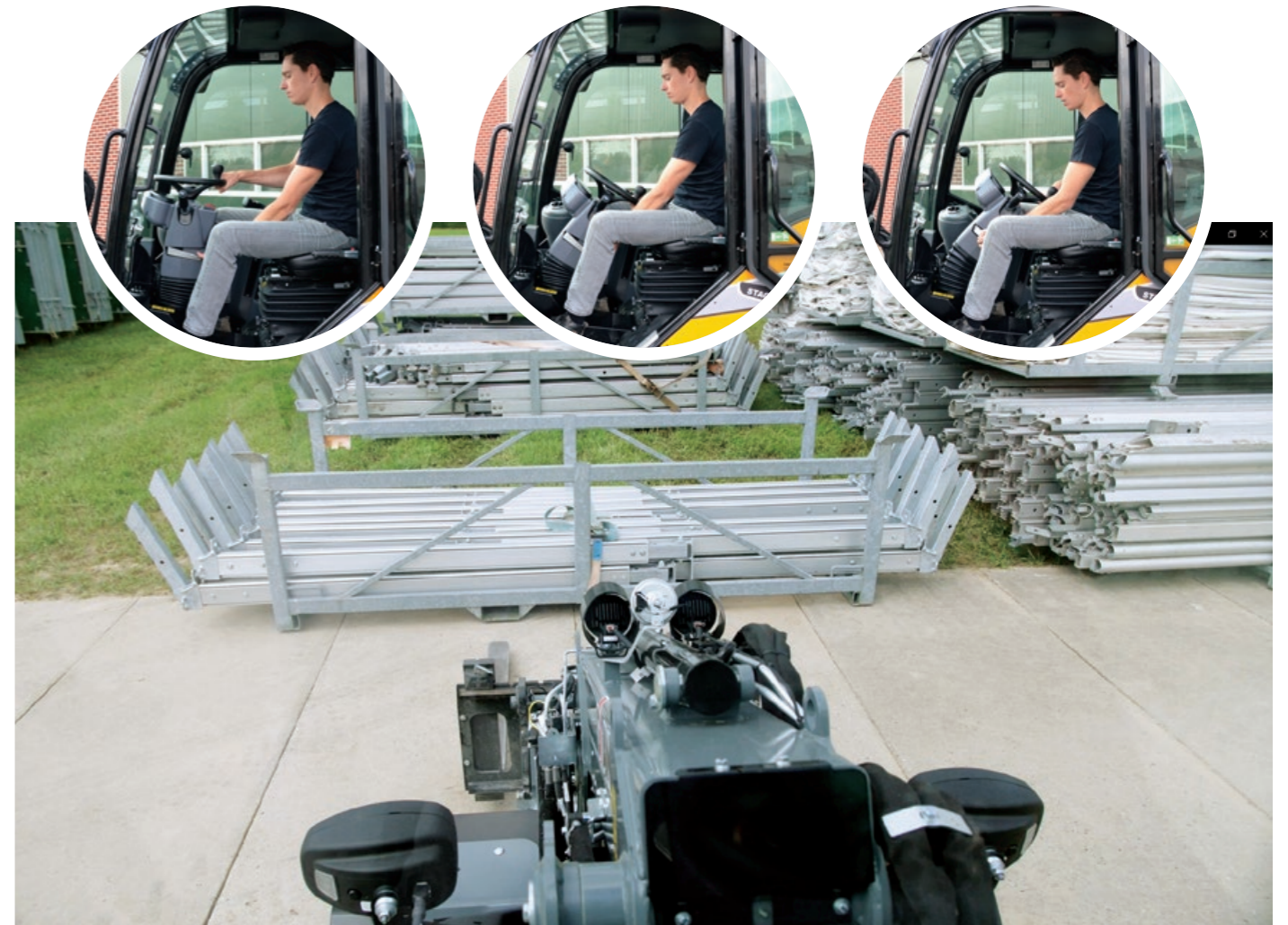

ATTACHMENTS

500+ attachments

Our attachments are developed entirely in-house so that they deliver the best results when working on our machines. TOBROCO-GIANT offers more than 500 different attachments so your machine can be used all year long. By choosing the right attachment it is possible to adjust your GIANT to working conditions for agricultural purposes, construction, material handling, private use and many other areas of application. Get every job done with just one machine!

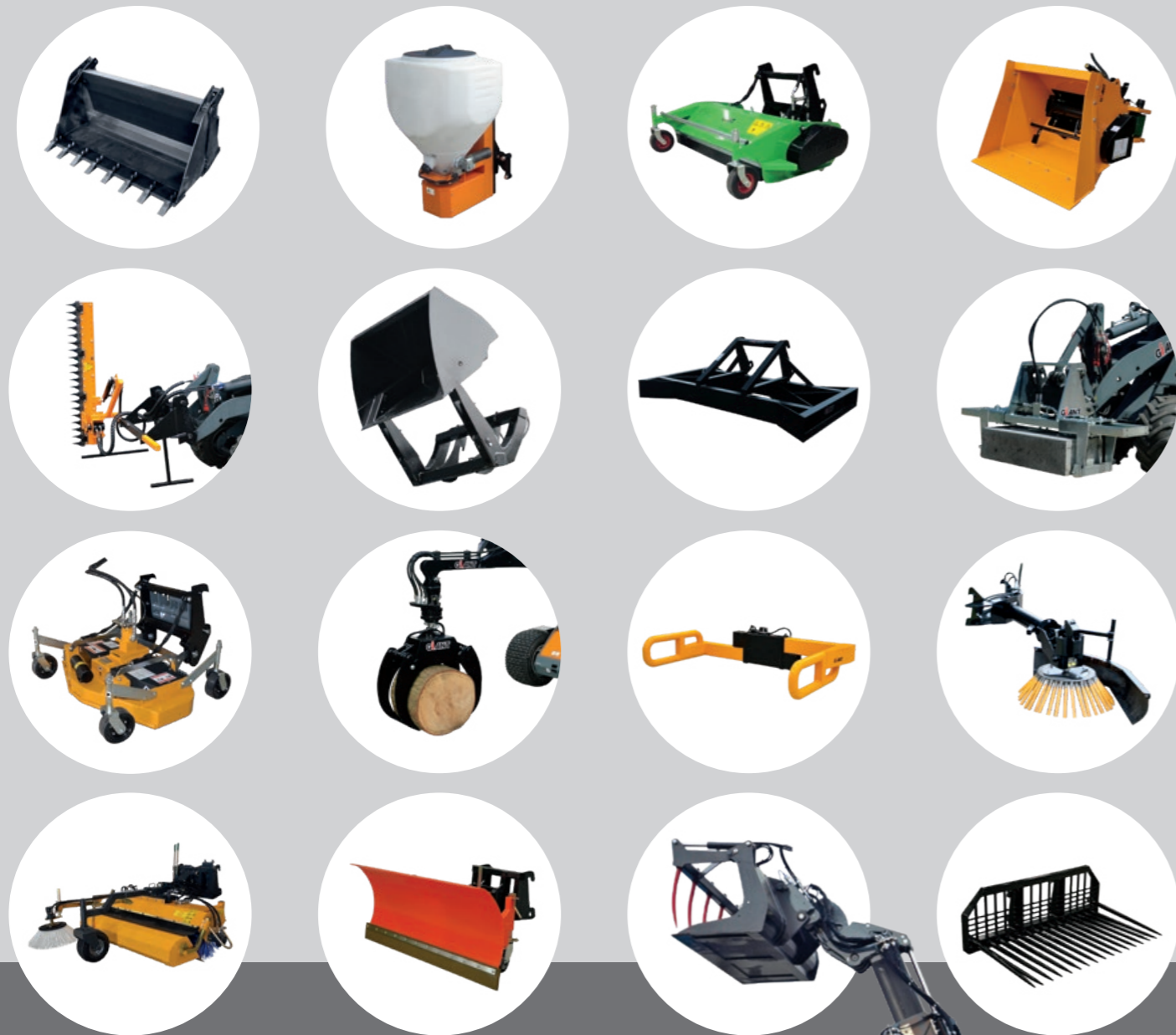

HYDRAULIC QUICK COUPLER

The G2700 models are standard equipped with a hydraulic quick coupler as a standard. This makes it possible to change attachments safely and within seconds.

MOUNTING SYSTEMS

TOBROCO-GIANT offers a wide range of mounting systems, enabling you to use the attachment that you already have.



SECTORS

One machine for every job



INFRASTRUCTURE



AGRICULTURAL



CONSTRUCTION & DEMOLITION



EQUINE INDUSTRY



FORESTRY



GOVERNMENT & MUNICIPALITIES



MATERIAL HANDLING



NURSERIES



WINTER SERVICE



LANDSCAPING & GROUND CARE

SPECIFICATIONS

TECHNICAL DATA

TYPE	G2700 HD	G2700 X-TRA HD	G2700 HD+	G2700 X-TRA HD+	G2700 TELE HD	G2700 TELE HD+
Service weight ¹	2.550 kg	2.550 kg	2.600 kg	2.600 kg	2950 kg	3000 kg
Lifting capacity	1.875 kg	2.325 kg	1.900 kg	2.350 kg	2325 kg	2350 kg
Tipping load ²	2.070 kg	2.220 kg	2.225 kg	2.455 kg	see graph page 17	see graph page 17
SIZE AND SPEED						
Lifting height ²	2.964 mm	2.500 mm	2.964 mm	2.500 mm	3711 mm	3711 mm
Length without bucket	3.405 mm	3.468 mm	3.405 mm	3.468 mm	3625 mm	3625 mm
Machine height ³	2.340 mm	2.340 mm	2.340 mm	2.340 mm	2340 mm	2340 mm
Width on standard types	1.100 mm	1.100 mm	1.140 mm	1.140 mm	1100 mm	1140 mm
Standard tyres	11.5/80-15.3 AS	11.5/80-15.3 AS	11.5/80-15.3 AS	11.5/80-15.3 AS	11.5/80-15.3 AS	0
Travel speed (depending on country choice and road specification)	0-10 km/h 0-25 km/h (with automatic gear)	0-10 km/h 0-25 km/h (with automatic gear)	0-10 km/h 0-30 km/h (with automatic gear)	0-10 km/h 0-30 km/h (with automatic gear)	0-10 km/h 0-25 km/h (with automatic gear)	0-10 km/h 0-30 km/h (with automatic gear)
ENGINE						
	Kubota D1803 CR DOC/DPF (STAGE V)			Kubota D1803 CR DOC/DPF (STAGE V)		
Cylinders	3			3		
Power	50 PK / 36 kW			50 PK / 36 kW		
Type	Turbo Diesel			Turbo Diesel		
Fuel tank capacity	47 l	30 l	47 l	30 l	30 l	30 l
Oil capacity	42 l	42 l	42 l	42 l	42 l	42 l
POWERTRAIN						
Type	Hydrostatic 4 wheel drive			Hydrostatic 4 wheel drive		
Transmission	Automotive control			Automotive control		
Differential	Limited slip on both axles			100% electrical differential lock on both axles		100% electrical differential lock
Final drive	8 tons planetary axles (HD version)	8 tons planetary axles (HD version)	12 tons planetary axles (HD version)	12 tons planetary axles (HD version)	8 tons planetary axles (HD version)	12 tons planetary axles (HD version)
Pulling force	20.000 N	20.000 N	28.000 N	28.000 N	20.000 N	28.000 N
Driving hydraulics	75 ltr/min (420 bar)	75 ltr/min (420 bar)	121 ltr/min (400 bar)	121 ltr/min (400 bar)	75 ltr/min (420 bar)	121 ltr/min (400 bar)
Working hydraulics	51 ltr/min (230 bar)	51 ltr/min (230 bar)	51 ltr/min (230 bar)	51 ltr/min (230 bar)	51 ltr/min (230 bar)	51 ltr/min (230 bar)
Parking brake	Drum brakes			Drum brakes		

STANDARD MACHINE FEATURES

TYPE	G2700 HD	G2700 X-TRA HD	G2700 HD+	G2700 X-TRA HD+	G2700 TELE HD	G2700 TELE HD+
GIANT hydraulic quick change system	Std	Std	Std	Std	Std	Std
ROPS/FOPS safety roof incl. safety doors left and right	Std	Std	Std	Std	Std	Std
Mechanically suspended seat incl. safety belt and armrest	Std	Std	Std	Std	Std	Std
1x Double acting hydraulic function on lifting arm, mechanical	Std	Std	Std	Std	Std	Std
Floating position of lifting cylinder(s)	Std	Std	Std	Std	N/A	N/A
Hydraulic servicebrake on 4 wheels	Std	Std	Std	Std	Std	Std
Working light (halogen) front, on lifting arm	Std	Std	Std	Std	Std	Std
Battery, 77 Ah	Std	Std	Std	Std	Std	Std
Main switch	Std	Std	Std	Std	Std	Std
Anti-theft protection with access code	Std	Std	Std	Std	Std	Std
Towing hook at the back	Std	Std	Std	Std	Std	Std
Counterweight integrated into the bumper	Std	Std	Std	Std	Std	Std
Oil cooler	Std	Std	Std	Std	Std	Std

¹ Measured with standard version and earthbucket.

² Measured with hinge point in straight position on standard tyres.

³ Measured on standard tyres with safety roof.

SPECIFICATIONS

MEASUREMENTS

	G2700 HD	G2700 X-TRA HD	G2700 HD+	G2700 X-TRA HD+	G2700 TELE HD	G2700 TELE HD+
A Wheelbase	1.648 mm	1.700 mm	1.648 mm	1.700 mm	1.700 mm	1.700 mm
B Total length	3.405 mm	3.468 mm	3.405 mm	3.468 mm	3.678 mm	3.678 mm
C Length with bucket	4.177 mm	4.239 mm	4.177 mm	4.239 mm	4.239 mm	4.239 mm
D Seat height	1.380 mm	1.380 mm	1.380 mm	1.380 mm	1.380 mm	1.380 mm
E Max. height with safety roof	2.340 mm	2.340 mm	2.340 mm	2.340 mm	2.340 mm	2.340 mm
Max. height with cabin	2.340 mm	2.340 mm	2.340 mm	2.340 mm	2.340 mm	2.340 mm
F Height front frame	1.753 mm	1.513 mm	1.753 mm	1.513 mm	1.513 mm	1.513 mm
G Max. dump height	2.209 mm	1.753 mm	2.209 mm	1.753 mm	2.870 mm	2.870 mm
H Lifting height	2.984 mm	2.517 mm	2.984 mm	2.517 mm	3.711 mm	3.711 mm
I Height with bucket	3.572 mm	3.104 mm	3.572 mm	3.104 mm	4.367 mm	4.367 mm
J Rollback angle on the ground	45°	42°	45°	42°	42°	42°
K Rollback angle at max. lift height	53°	46°	53°	46°	55°	55°
L Max. angle for bucket emptying	37°	37°	37°	37°	35°	35°
M Drive-up angle	25°	25°	25°	25°	25°	25°
N Outer size of tires	ø 850 mm	ø 850 mm	ø 850 mm	ø 850 mm	ø 850 mm	ø 850 mm
1A Turning radius with bucket	1.100 mm	1.100 mm	1.140 mm	1.140 mm	1.200 mm	1.200 mm
1B Turning radius on outer edge	2.972 mm	3.045 mm	2.972 mm	3.045 mm	3.160 mm	3.160 mm
1C Inner turning radius	2.560 mm	2.623 mm	2.560 mm	2.623 mm	2.611 mm	2.611 mm
1D Width on standard tyres	1.100 mm	1.100 mm	1.140 mm	1.140 mm	1.100 mm	1.140 mm

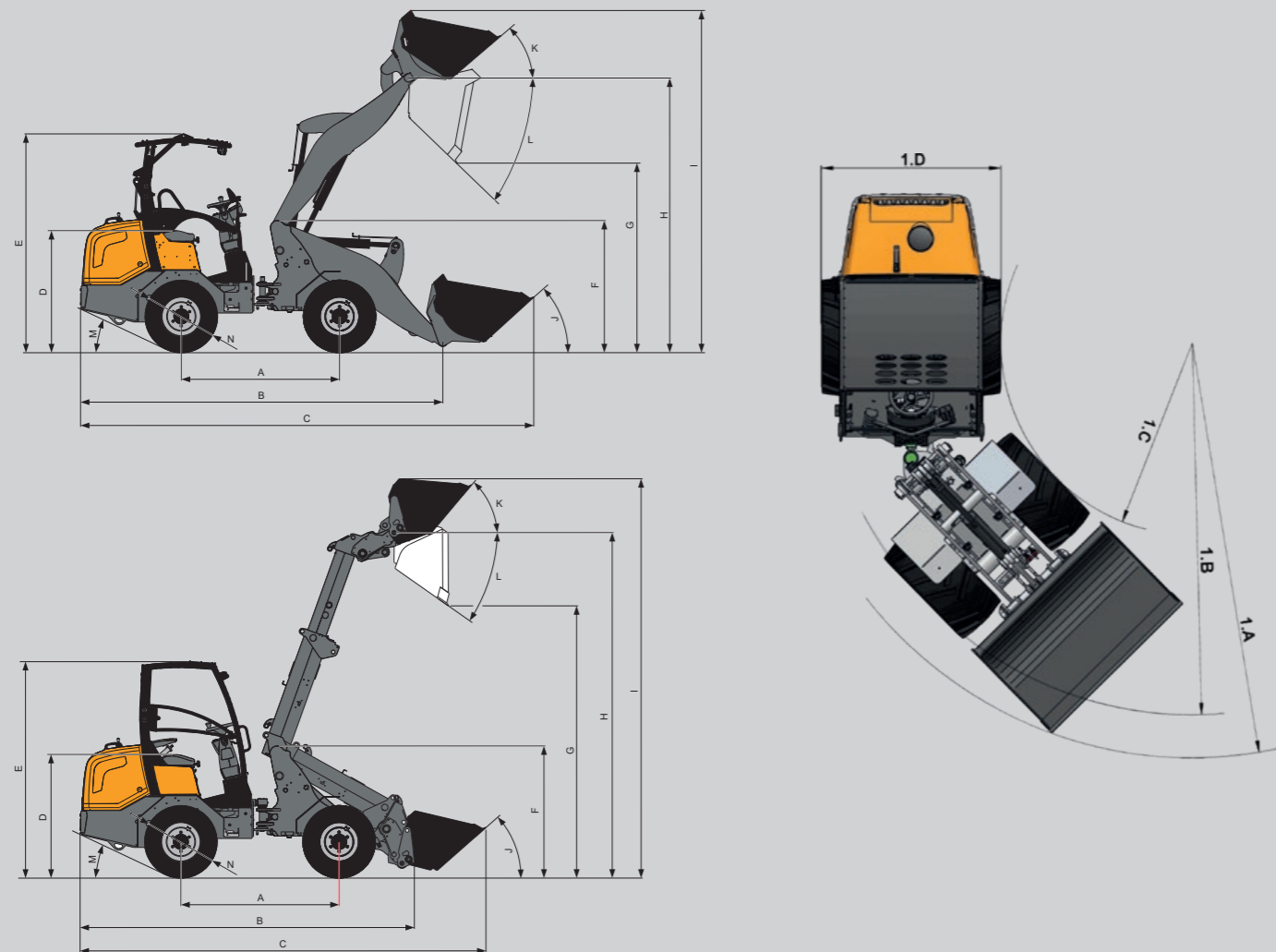

TIPPING LOADS

	G2700 HD	G2700 X-TRA HD	G2700 HD+	G2700 X-TRA HD+
S	1.855 kg	2.430 kg	2.050 kg	2.715 kg
T	1.725 kg	2.235 kg	1.905 kg	2.490 kg
U	1.340 kg	1.695 kg	1.480 kg	1.865 kg
V	1.050 kg	1.300 kg	1.160 kg	1.420 kg
W	2.990 kg	3.150 kg	3.200 kg	3.550 kg
X	2.070 kg	2.220 kg	2.225 kg	2.455 kg
Y	1.475 kg	1.600 kg	1.590 kg	1.750 kg

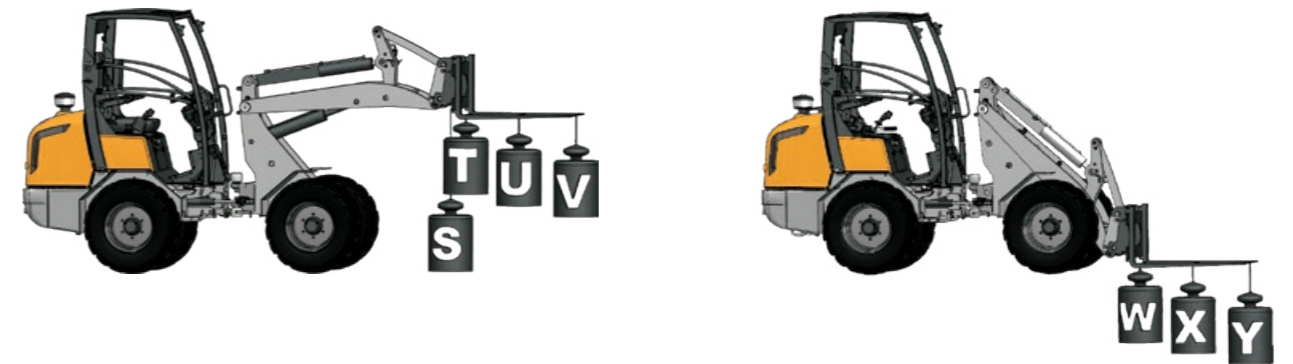

TIPPING LOADS GRAPH G2700 TELE HD

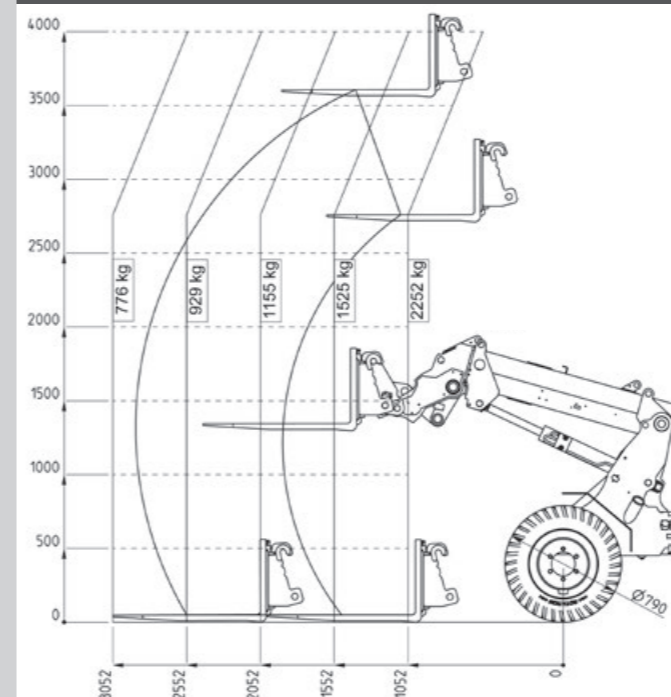

TIPPING LOADS GRAPH G2700 TELE HD+

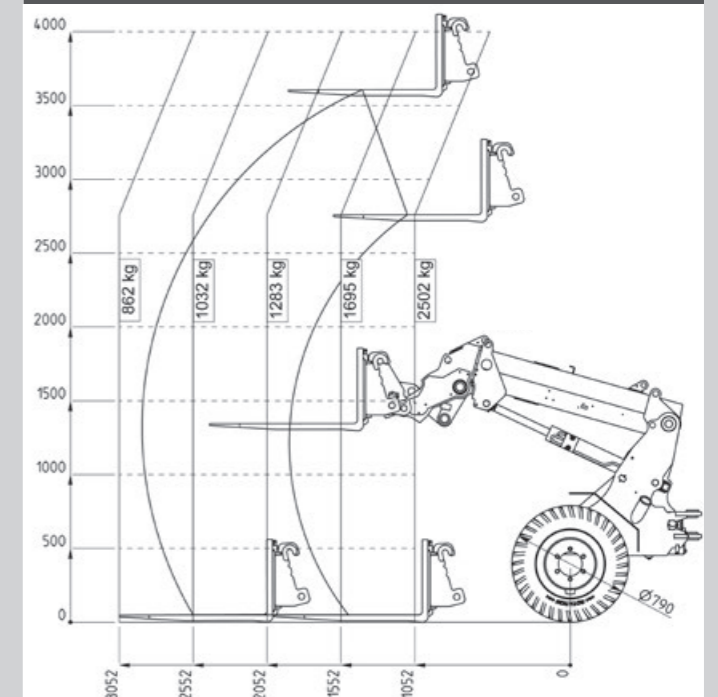

For off road use, divide the tipping load by 1.67 because of the legal safety factor.

Tipping load = without counterweights.

Measured with GIANT hitch. The above values may deviate for other types of hitches.

AVAILABLE OPTIONS

	G2700 HD	G2700 X-TRA HD	G2700 HD+	G2700 X-TRA HD+	G2700 TELE HD	G2700 TELE HD+
CABIN						
ROPS/FOPS safety roof deluxe incl. front and rear window, front screen wiper, safety doors, 2 side mirrors, 2 working lights (halogen) front and 2 rear	0	0	0	0	0	0
Glass doors, set (L+R)	0	0	0	0	0	0
Heating (only possible in combination with glass doors set)	0	0	0	0	0	0
ROPS/FOPS foldable safety roof incl. safety doors (clearance height with folded safetyroof: 1.980 mm)	0	0	0	0	-	-
ROPS/FOPS foldable safety roof deluxe incl. safety doors, 2 side mirrors, 2 working lights (halogen) front and 2 rear	0	0	0	0	0	0
ROPS/FOPS Cabin incl. heating, FM/AM radio and speakers, 2 side mirrors, 2 working lights (halogen) front and 2 rear	0	0	0	0	0	0
FM/AM radio and speakers	0	0	0	0	0	0
DAB+ radio and speakers (bluetooth and USB 2.0 connection)	0	0	0	0	0	0
Cabin mat	0	0	0	0	0	0
Mechanically suspended seat with seat heating incl. safety belt and armrest	0	0	0	0	0	0
Air suspended seat incl. safety belt and armrest	0	0	0	0	0	0
Air suspended seat with seat heating incl. safety belt and armrest	0	0	0	0	0	0
Side mirrors (L+R)	0	0	0	0	0	0
ROPS roll bar conversion set	0	0	0	0		
HYDRAULIC CONNECTIONS ON LIFTING ARM						
Hose rupture protection on lift and top cylinder + transport securing device (floating position expires)	0	0	0	0	Std	Std
Hose rupture protection on lift and top cylinder + floating position + transport securing device	0	0	0	0	-	-
Transport securing device	0	0	0	0	Std	Std
1x double acting hydraulic function, proportional in joystick with memory function	0	0	0	0	0	0
1x extra double acting hydraulic function, mechanical	0	0	0	0	0	0
1x extra double acting hydraulic function, proportional in joystick with memory function	0	0	0	0	0	0
2x extra double acting hydraulic function, proportional in joystick with memory function	0	0	0	0	0	0
1x extra double acting hydraulic function, mechanical + 1x extra double acting hydraulic function, proportional in joystick	0	0	0	0	0	0
Electrically switchable tandem pump (max. 60 ltr/min, 150 bar), 1x extra single acting hydraulic function + free return	0	0	0	0	0	0
Electrically switchable tandem pump (max. 16 ltr/min 150 bar) for laser board, 1x extra single acting hydraulic function + free return	0	0	0	0	0	0
Combi-Flow max. 70 ltr/min	0	0	0	0	0	0
Single- or double-side hydraulic hold on additional function	0	0	0	0	0	0
Leak oil connection	0	0	0	0	0	0
Free hydraulic return	0	0	0	0	0	0
HYDRAULIC CONNECTIONS AT THE BACK						
1x extra double acting hydraulic function, mechanical 51 ltr/min (230 bar)	0	0	0	0	0	0
1x extra double acting hydraulic function, proportional in joystick with memory function 51 ltr/min (230 bar)	0	0	0	0	0	0
Electrically switchable tandem pump, max. 60 ltr/min (1x extra single acting hydraulic function + free return)	0	0	0	0	0	0
Leak oil connection	0	0	0	0	0	0
Free return	0	0	0	0	0	0
Three point lifting mechanism (Cat. 1) incl. 1x extra double acting hydraulic function, mechanical	0	0	0	0	0	0
Three point lifting mechanism (Cat. 1) incl. 1x extra double acting hydraulic function, proportional in joystick	0	0	0	0	0	0
ELECTRICAL / LIGHTING						
Switched 12 Volt socket, 3-pin (max. 2)	0	0	0	0	0	0
13-pin trailer socket to the back	0	0	0	0	0	0
Additional working light (halogen or LED) front, on lifting arm	0	0	0	0	0	0
Additional working light (halogen or LED) front, on safetyroof (max. 2)	0	0	0	0	0	0
Additional working light (halogen or LED) rear, on safetyroof (max. 2)	0	0	0	0	0	0
Flashing/warning light (halogen or LED) on safetyroof (max. 2)	0	0	0	0	0	0
2x Flashers (LED) front + 2x Flashers (LED) rear	0	0	0	0	0	0
Engine heater (Coolant) 110V or 220V	0	0	0	0	0	0
Traffic lights (halogen or LED)	0	0	0	0	0	0
License plate holder with illumination (only possible in combination with traffic lights, halogen or LED)	0	0	0	0	0	0
OTHER OPTIONS						
Machine sprayed in RAL company colour	0	0	0	0	0	0
STABLO system (Patented)	0	0	0	0	0	0
Hand throttle	0	0	0	0	0	0
Hand throttle EPC	-	-	0	0	0	0
Hand inching	0	0	0	0	0	0
Pro-inching EPC	-	-	0	0	0	0
Back-up alarm (acoustic)	0	0	0	0	0	0
Jump start	0	0	0	0	0	0
Mudguard wideners	0	0	0	0	0	0
Shunt coupling (standard) + Tow ball	0	0	0	0	0	0
Towing hitch, automatic	0	0	0	0	0	0
Towing hitch, automatic + Tow ball	0	0	0	0	0	0
Counterweight 62 kg (max. 2 pcs) under machine	0	0	0	0	0	0
Different hitch	0	0	0	0	0	0
Boom suspension	0	0	0	0	-	-
Parallel indicator on tilt cylinder	0	0	0	0	-	-
Document box	0	0	0	0	0	0
Panolin HLP Synth 46 biodegradable hydraulic fluid	0	0	0	0	0	0
Road specification (ask your dealer for details)	0	0	0	0	0	0

MAINTENANCE



Performing maintenance to the G2700 is no problem at all because the service points are easy to reach. Filters, hydraulic system and engine can be freely accessed via the easy-to-open bonnet, tilting cab or other service panels. This ensures that daily checks and maintenance can be carried out quickly and in a safe manner.

GENUINE GIANT PARTS



The usage of genuine GIANT parts ensures reliable, efficient and safe operation of your machine. We only use the best quality components and test them severely before we introduce a new model. All these parts are vital for the best possible performance and minimising downtime. Keeping your GIANT 100% original saves money for the owner because of reduced maintenance costs and results in a higher resale value once the machine is resold.

SERVICE & SUPPORT



At TOBROCO-GIANT we offer support, service and high quality parts to protect the investment that you have made in GIANT machinery. Together with our dealers we are available to make sure that your machine performs in the best possible way. This increases your productivity and will result in an even better return on your investment.

TRAINING



At TOBROCO-GIANT we know all the details about our machines. That is why we offer an extensive training program to our dealers. Not only on the newest features or attachments, but also on how to service a machine to the highest standards.

“It is very important that we can have the GIANT loader on the car trailer, without driving with weight overload. The loader is indispensable for us.”

Kirsten Falster-Hansen, Creative Have ApS in Janderup.





Quality - Growth - Innovation - Integrity -
Customer Oriented - Enterprising

*“Developed in
The Netherlands, built for
the world”*

Over 25 years, TOBROCO-GIANT has grown into a global player in compact machines with one of the broadest portfolios in the industry. The wide range of implements ensures that all work can be carried out with one machine. This means that GIANT machines can be used all year round for all kinds of work.

In a modern factory in the Netherlands, machines and attachments are developed and produced in-house. By using the state-of-the-art technology, ensuring continuous innovation and applying the best components from Kubota, Bosch Rexroth and Comer, GIANT machines and attachments are produced with exceptional care for quality.

Every day, the team of more than 500 employees in the Netherlands, Hungary and America focuses with passion and enthusiasm on complete customer satisfaction.

THE FUTURE IS ELECTRIC

The demand for compact electrical equipment is an unstoppable trend. With Jungheinrich, TOBROCO-GIANT has found a global and reliable partner with expertise when it comes to developing electrical machines. Everything is aimed at developing an electric version of each GIANT along to the diesel version in the long term.

DEALER NETWORK

With a large network of dedicated dealers we like to be close to our customers to provide the machines, service and parts that you demand. All dealers are supported by a team of experts from the head office of TOBROCO-GIANT in Oisterwijk, The Netherlands.

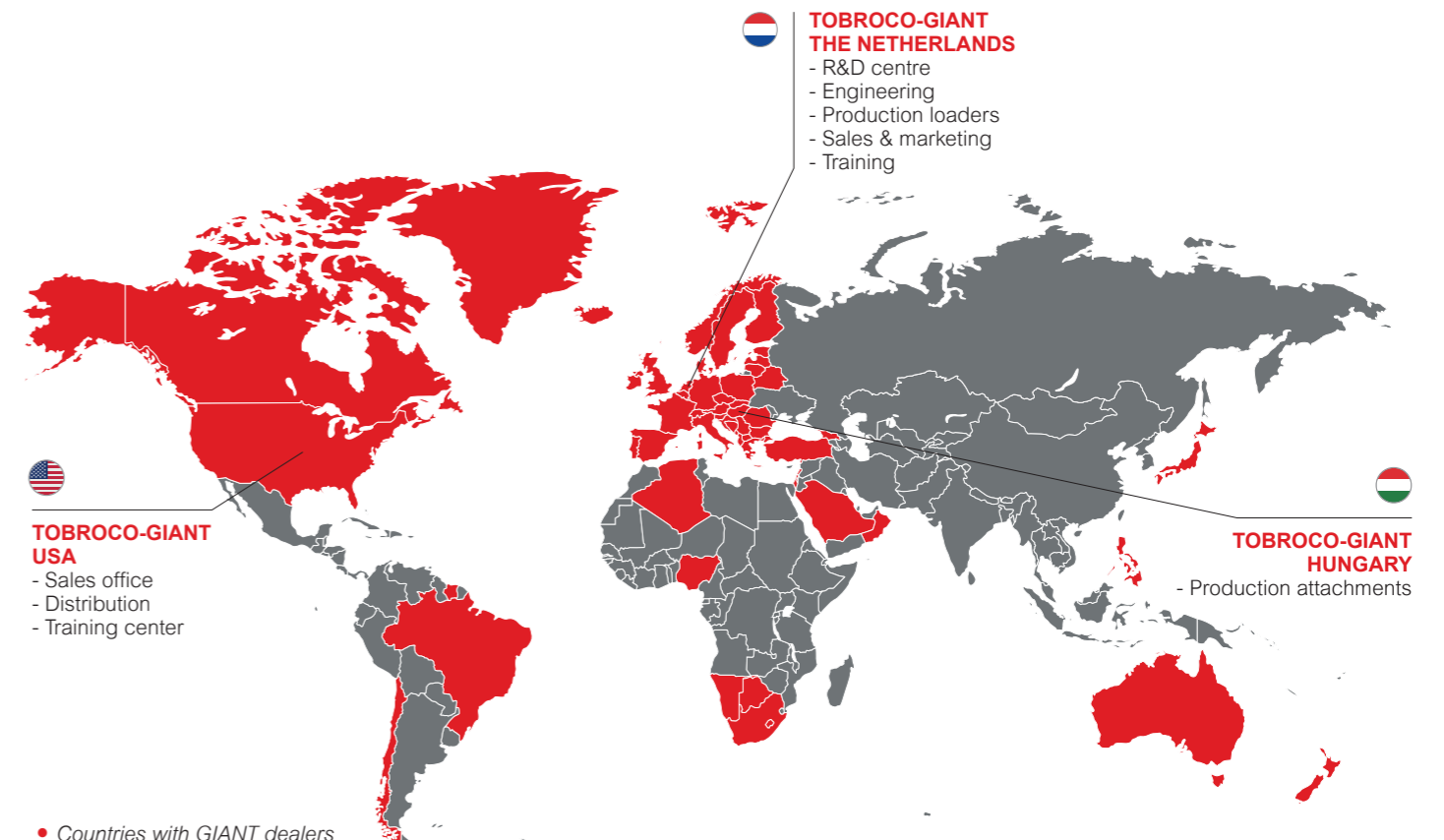

ALL MODELS

TOBROCO-GIANT has been manufacturing high-quality GIANT machines and attachments since 1996 when we opened our first factory in The Netherlands. Today, TOBROCO-GIANT offers one of the broadest product portfolios in the business with 35 different models sold in 60 countries. In addition to machines with motors from 20 hp to 76 hp, TOBROCO-GIANT also supplies electrical machines and a complete line of compaction machines. TOBROCO-GIANT grows into a full-liner in compact and durable equipment.



GS800G GS850T
GS800 GS950T
GS900

G1100 (TELE)
G1200 (TELE)

G1500 (X-TRA)

G2200E (X-TRA) 

G2300 (X-TRA) HD

G2500 (X-TRA) HD

G2700 (X-TRA / TELE) HD
G2700 (X-TRA / TELE) HD+
G2700E (X-TRA / TELE) 

G3500 (X-TRA / TELE)

G5000 (X-TRA / TELE)

GT5048

VIBRATORY PLATES
E-VIBRATORY PLATES 

VIBRATORY RAMMERS
E-VIBRATORY RAMMERS 

REVERSIBLE VIBRATORY PLATES
E-REVERSIBLE VIBRATORY PLATES 

 *Electric*



GIANT[®]
BY TOBROCO

TOBROCO-GIANT
Sprendlingenstraat 57, 5061 KM Oisterwijk (The Netherlands)
Tel.: +31 (0)13-5211212 | Fax: +31 (0)13-5234045
Internet: www.tobroco-giant.com | E-Mail: info@tobroco-giant.com

Artikelnummer en versienummer:
P00132700ENG V123



All technical data in this brochure refer to under Central European operating conditions tested series models and describe the standard functions. Specifications and their modes of operation, as well as accessories, depend on the model and the options of the product, as well as country-specific regulations in the country of sale. Images may show non-listed or non-standard available products. The descriptions, illustrations, weights and technical data are not binding and are in accordance with the state of the art at the time of going to press. Changes in the design, equipment, optics and technology are due to the continuous development of its products without prior notice. Do you need special functions which are only available through the use of additional components and / or under special circumstances, please contact us! We will be happy to answer your questions and let you know whether and under what conditions regarding the product and the environmental conditions special functions are realizable. When doubts about the capacity or the performance of our products under special circumstances, we recommend to perform under controlled conditions. Testing activities despite the utmost care, we cannot rule out deviations from illustrations or dimensions, calculation errors, misprints or omissions in this brochure. We therefore accept no liability for the correctness and completeness of the information contained in this brochure. As part of our General Terms and Conditions, we guarantee the proper functioning of our products. Furthermore Linear guarantees we provide in principle. A further liability than outlined in our Terms and Conditions is excluded.



CONNECT WITH US